



UNIVERSITY OF ILLINOIS
AT URBANA-CHAMPAIGN

AC Measurement of Magnetic Susceptibility

Physics 401, Spring 2013
Eugene V. Colla



Outline

- **Ferromagnetism**
- **Measurement of the magnetic properties of the materials**
- **Lab experimental setup and experiments**
- **Some results**



Ferromagnetism. Definition.

Some materials below a **certain temperature (T_c)** give rise to the magnetic field in absence of an applied field.

This magnetization is called **spontaneous**, the phenomenon – ferromagnetism and materials exhibiting this feature – ferromagnetics.

The main parameter of the ferromagnetic phase transition is **spontaneous magnetization**

Typical behavior of spontaneous magnetization as function of temperature

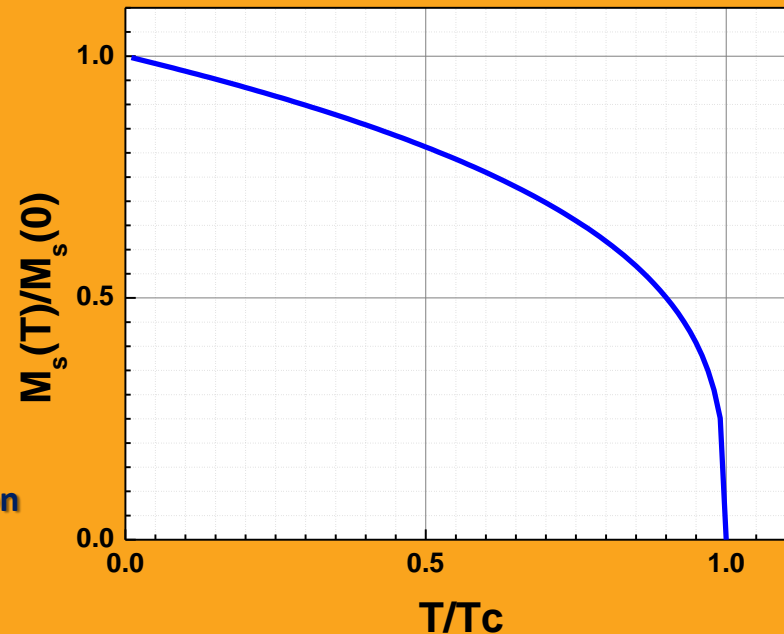

Ferromagnetic materials.



Aleksandr Stoletov
(1839 –1896)

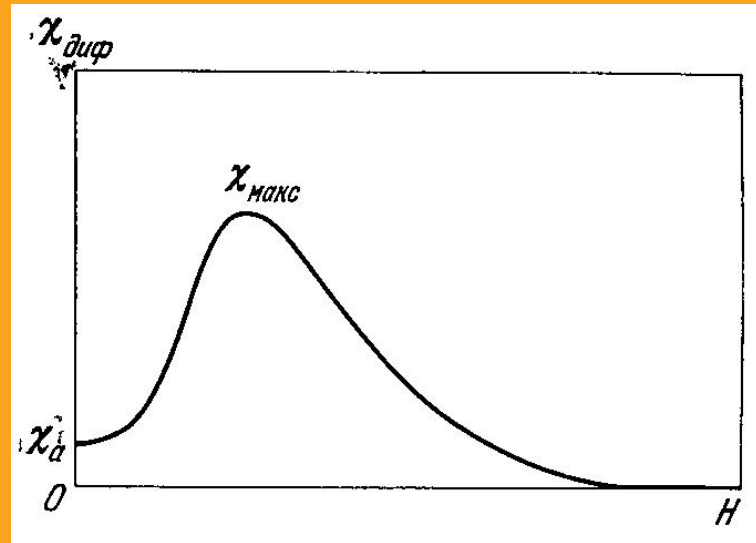

“Stoletov” curve

Material	Curie temp. (K)
Co	1388
Fe	1043
Fe ₂ O ₃ *	948
FeOFe ₂ O ₃ *	858
NiOFe ₂ O ₃ *	858
MgOFe ₂ O ₃ *	713
MnBi	630
Ni	627
MnSb	587
MnOFe ₂ O ₃ *	573
Y ₃ Fe ₅ O ₁₂ *	560
CrO ₂	386
MnAs	318
Gd	292

Stoletov performed pioneer works in area of ferromagnetic materials but better known by his research in photoelectric effect.

Domains. Hysteresis loop.

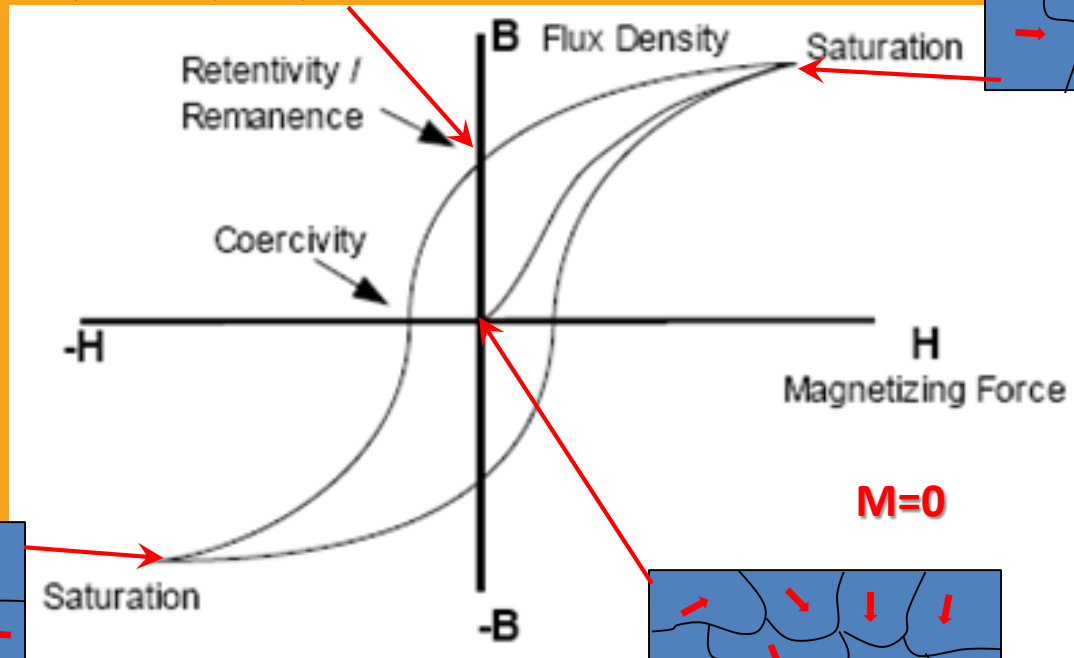
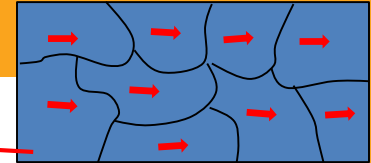
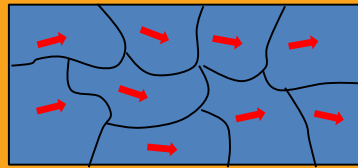

$$M \sim M_s$$

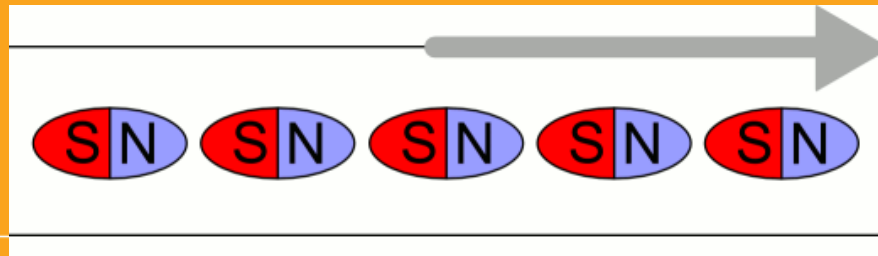
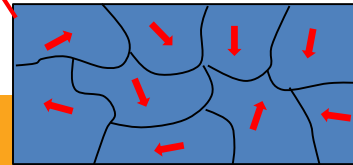
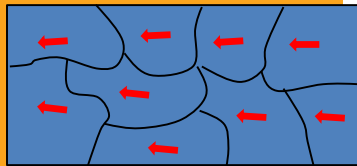

* Courtesy Wikipedia



Domains

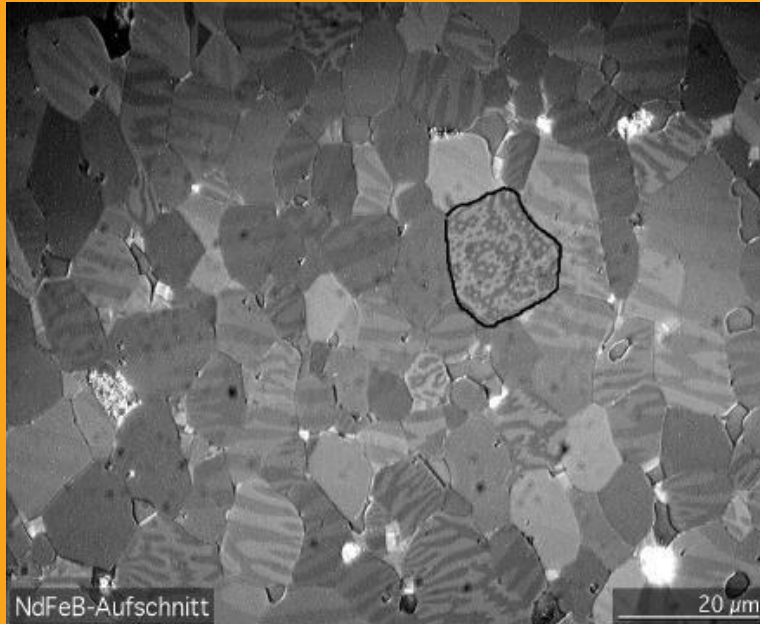

Several grains of NdFeB with magnetic domains made visible via contrast with a Kerr microscope.

Courtesy of Wikipedia

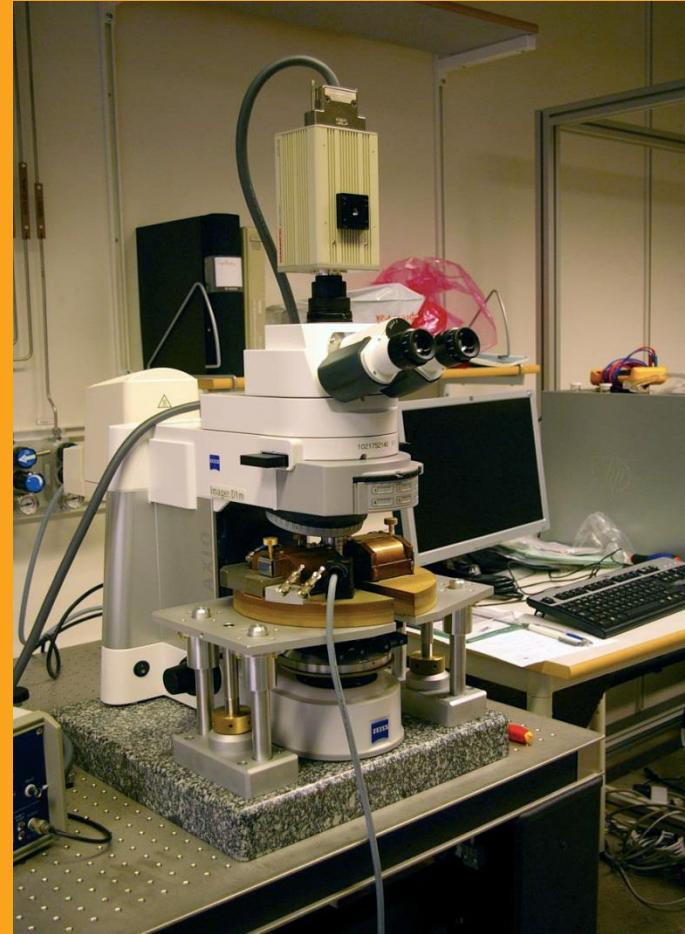

Kerr microscope
Courtesy of University of
Uppsala (Sweden)

Domains

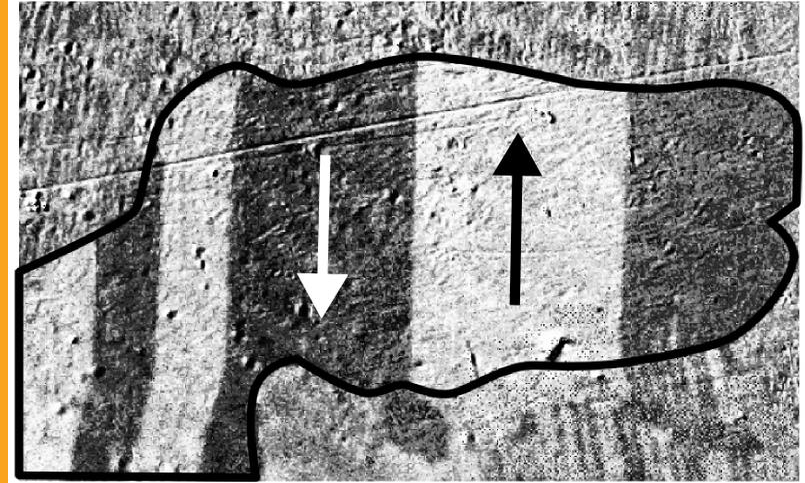
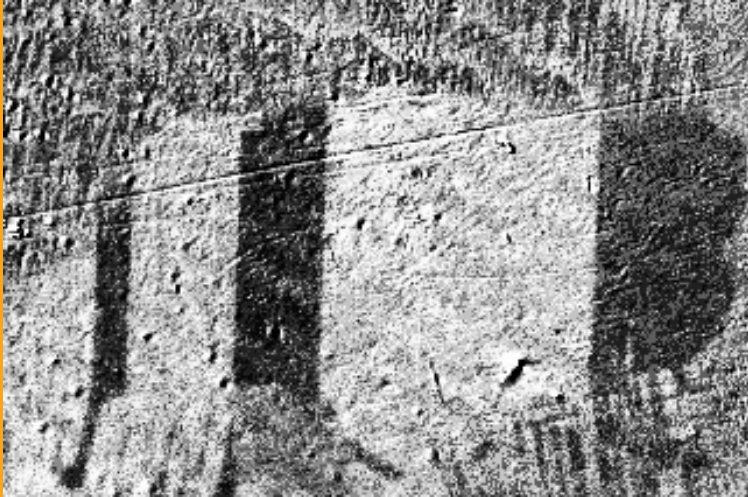

Moving domain walls in a grain of silicon steel caused by an increasing external magnetic field

Courtesy of Wikipedia

Hysteresis Loops.

Remagnetization loses

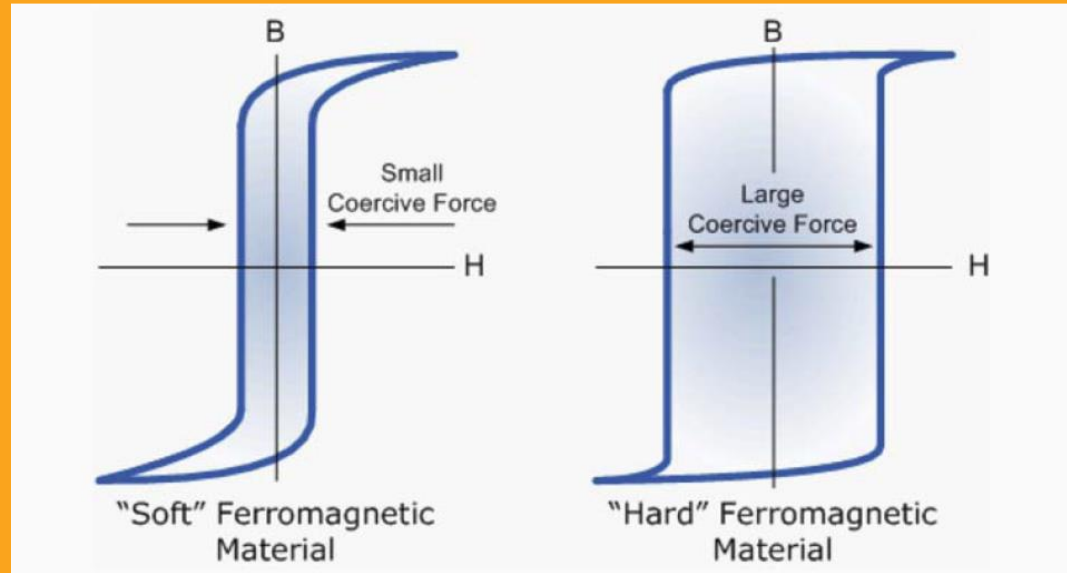

Energy of the magnetic field

$$W = V \int H dB$$

By cycling around the loop

$$W_{loop} = V \oint H dB = V * Loop_area$$

“Hard” materials. Application.

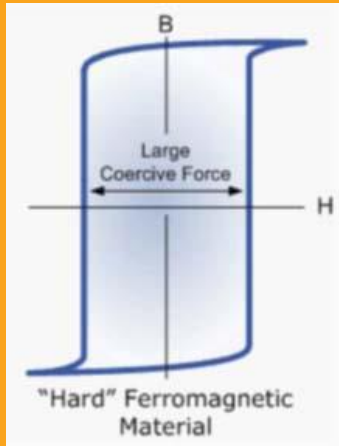

RAM memory

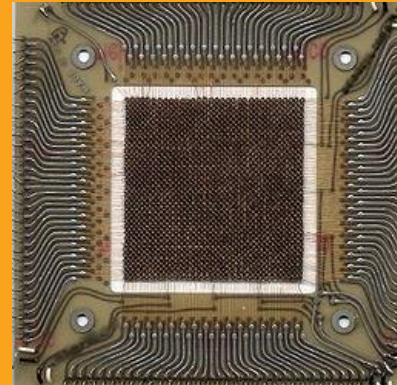
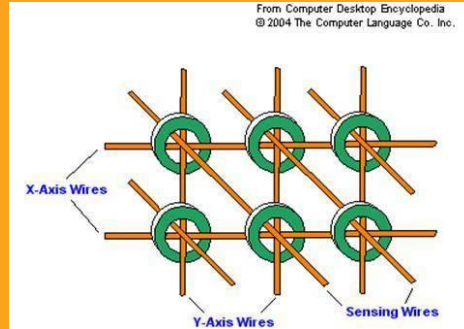

Permanent magnets



Hard drives, floppy, magnetic tape



“Soft” materials. Application.

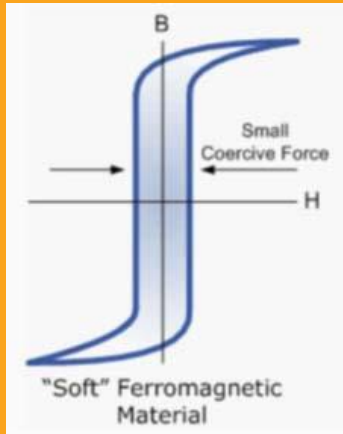

Chokes, inductors



Power transformers



Magnetic Field, Susceptibility etc.

$$B = \mu_0 (H + M)$$

B – magnetic induction

M – magnetization, in general $M(H)$

$$M = \chi H$$

χ – magnetic susceptibility,
in general $\chi(H)$

$$B = \mu_0 (1 + \chi) H = \mu_0 \mu_r H = \mu H$$

$$\mu = \mu_0 \mu_r = \frac{dB}{dH}; \quad \mu_r = \frac{1}{\mu_0} \frac{dB}{dH}$$



Modulation Spectroscopy

$$B = f(H) \quad H = H_0 + H_1 \sin \omega t$$

$$B = f(H_0) + \frac{df}{dH} (H_1 \sin \omega t) + \dots$$

$$H_1 = \text{const}$$

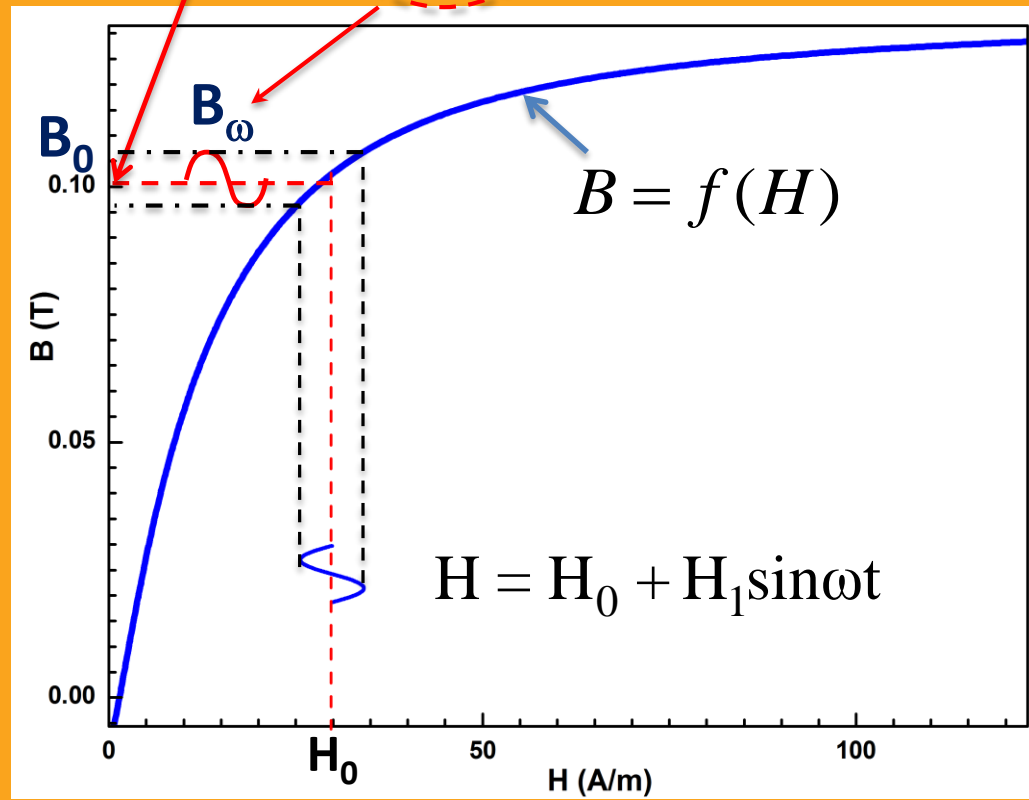

$$B_\omega \sim \frac{dB}{dH}$$



Measuring the magnetic permeability

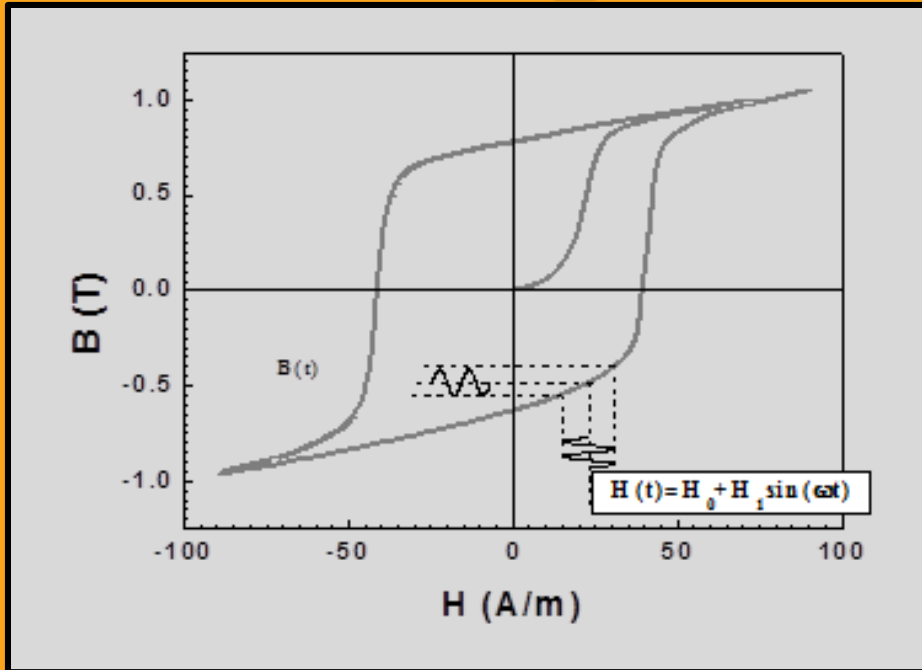

By applying a small modulation of the H field we can measure the derivative of the B - H hysteresis loop or dependence of the magnetic permeability on H field

$$\mu(H_0, \omega) = \mu_0(1 + \chi(H_0, \omega)) = \left. \frac{dB}{dH} \right|_{H_0, \omega}$$

Setup #1. Investigation of the hysteresis loops.



Setup #1. Investigation of the hysteresis loops.

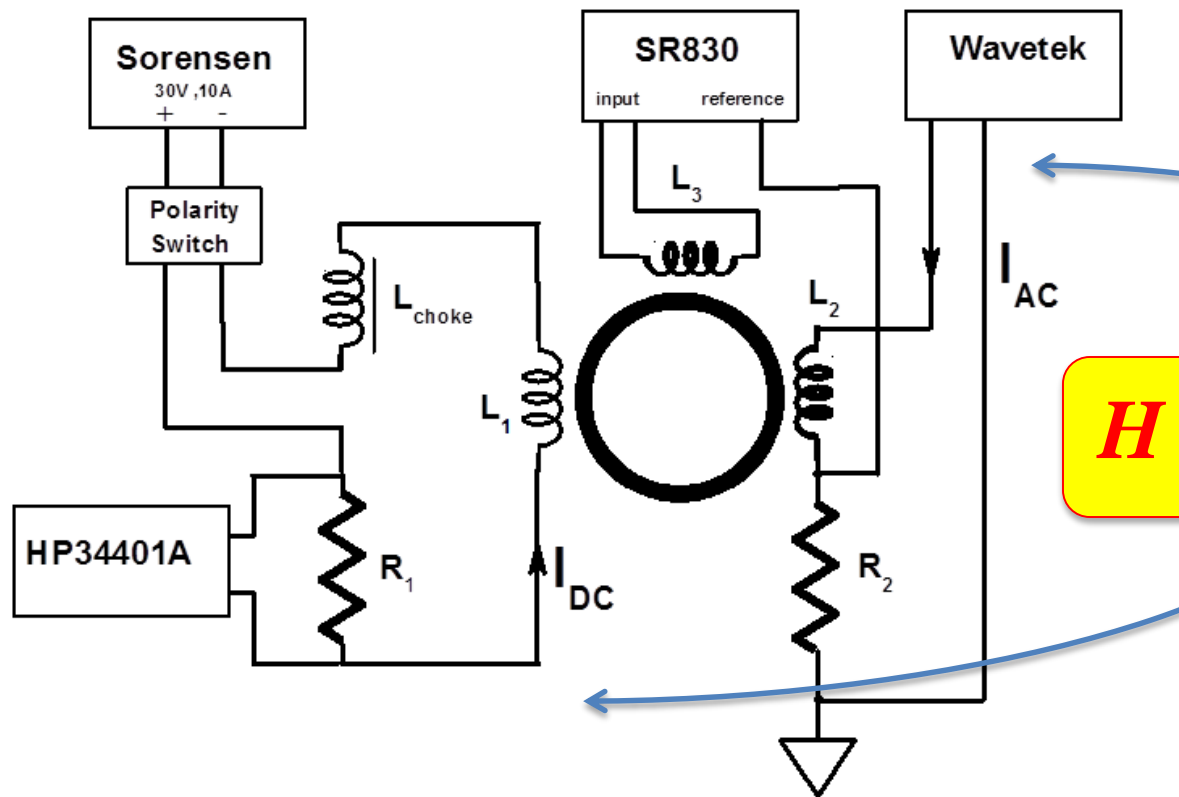

$$H = \frac{N_p I_p}{2\pi r}$$

$$H = H_0 + H_1 \cos \omega t$$

Major/minor loops. Demagnetization

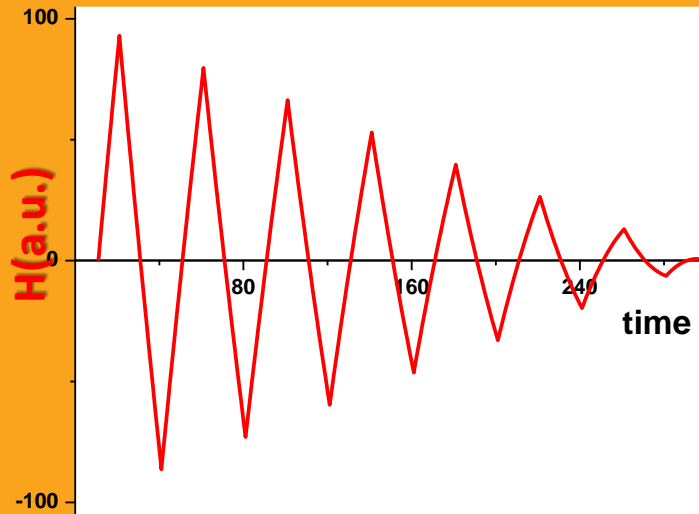

Waveform of H-field

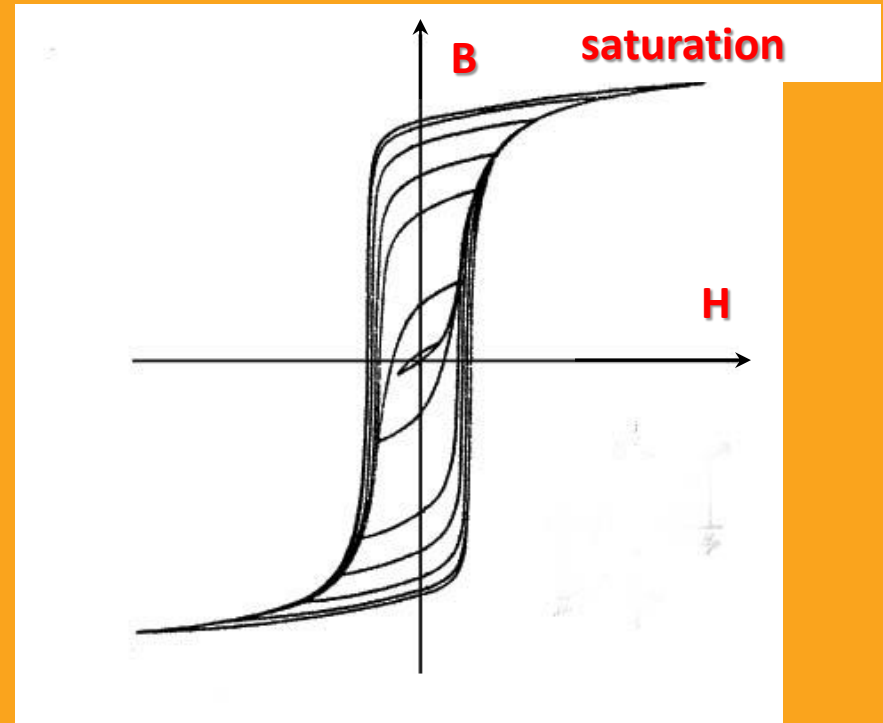
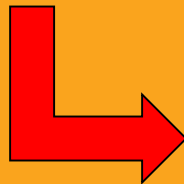

Demagnetization

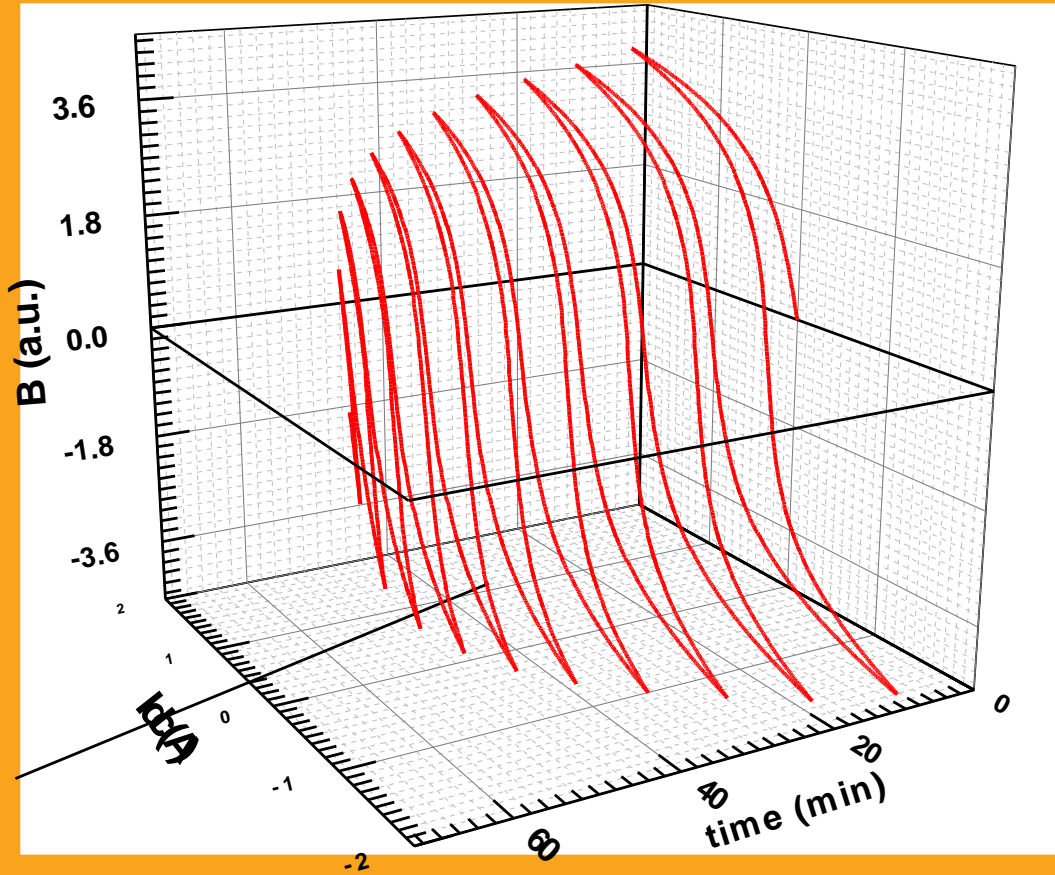

Demagnetization of 4C65 toroid
from Ferroxcube

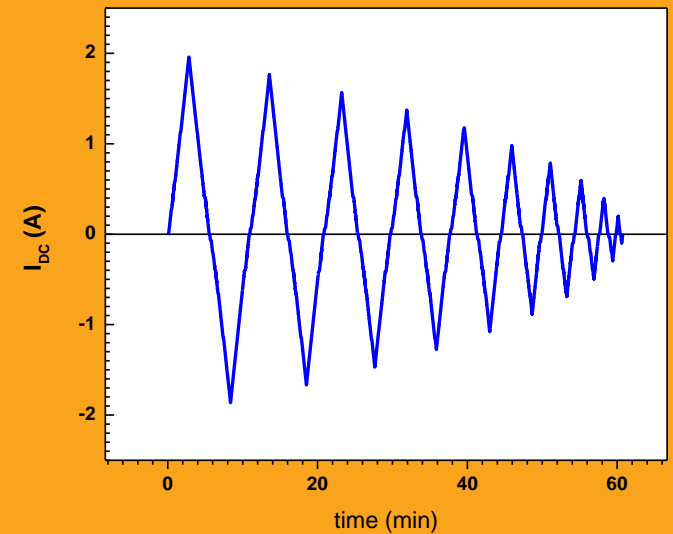

Hysteresis Loops

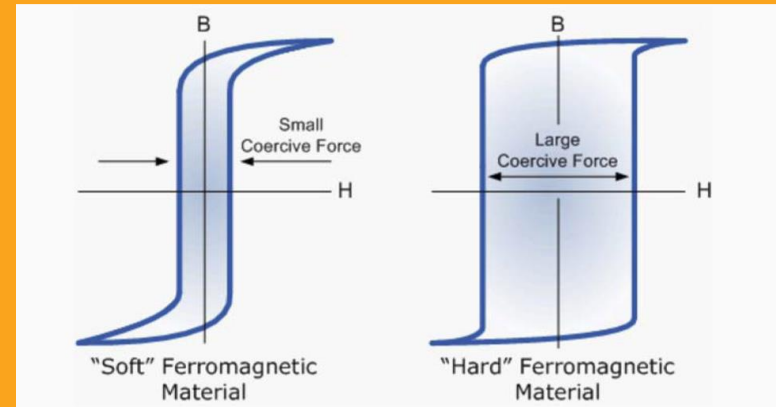
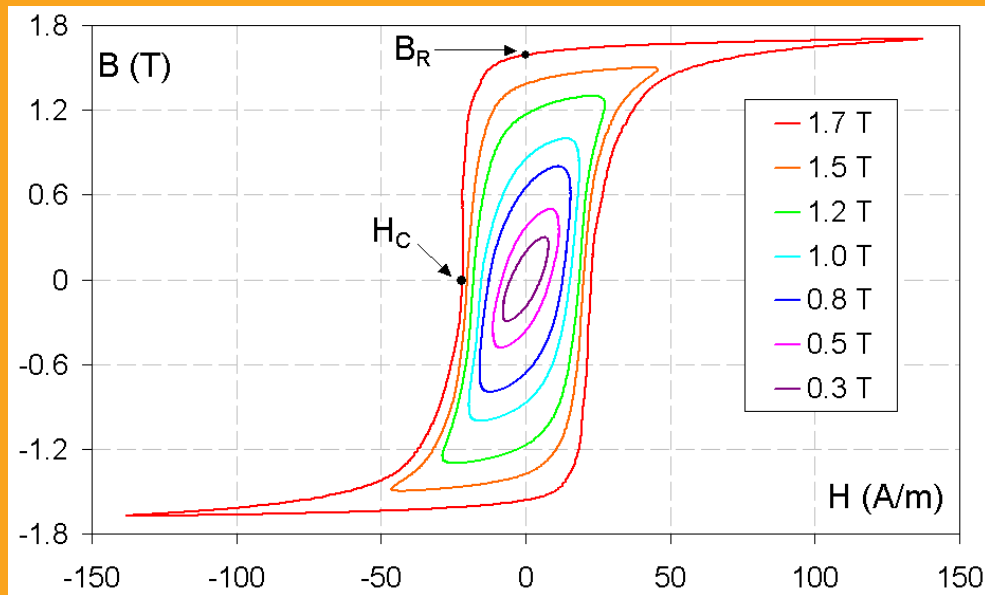
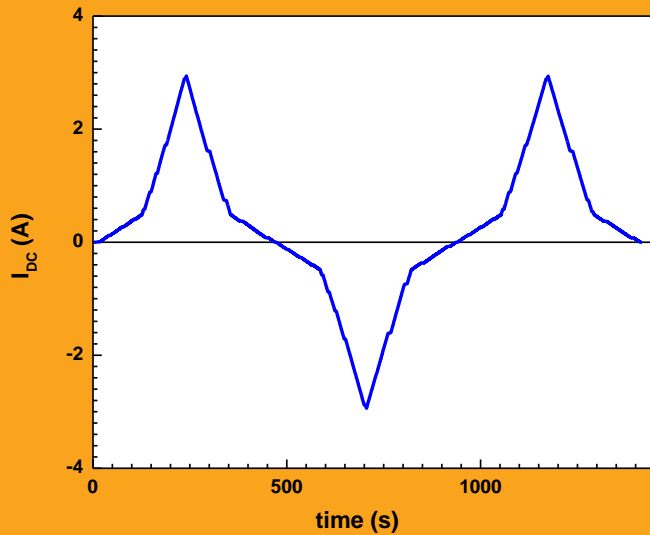
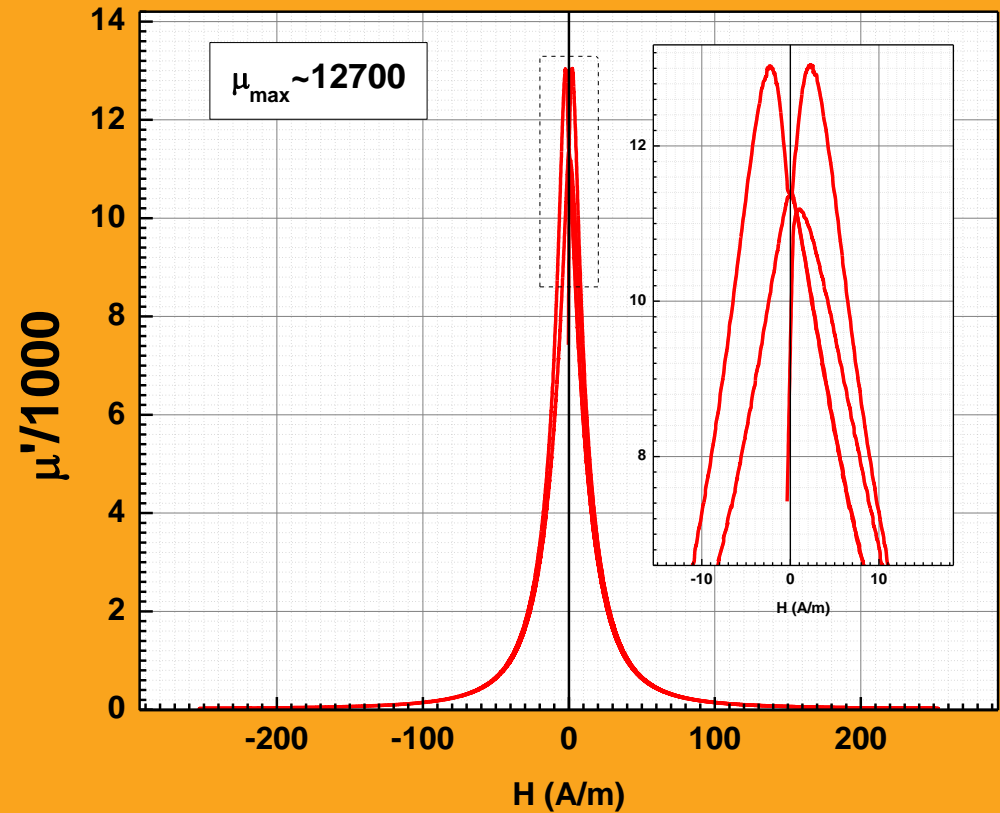

Fig. A family of AC hysteresis loops for grain-oriented electrical steel (B_R denotes remanence and H_C is the coercivity). Courtesy Zureks (Wikipedia)

Measuring the magnetic permeability



DC current profile and magnetic permeability of Magnetics ZW44715TC



From permeability to B-H hysteresis loop

Step#1. Performing one fast IDC scan the based on the result preparing the “smart” IDC profile

ECE storeroom unknown material Sample #5

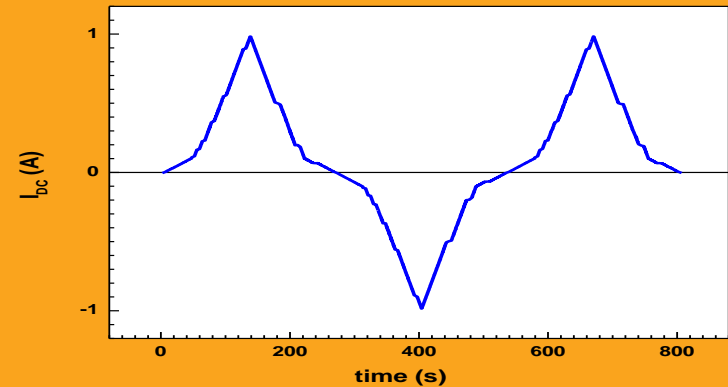

Step#2. Performing precise scan the. Plotting raw data based

Voltage units measured by SR830

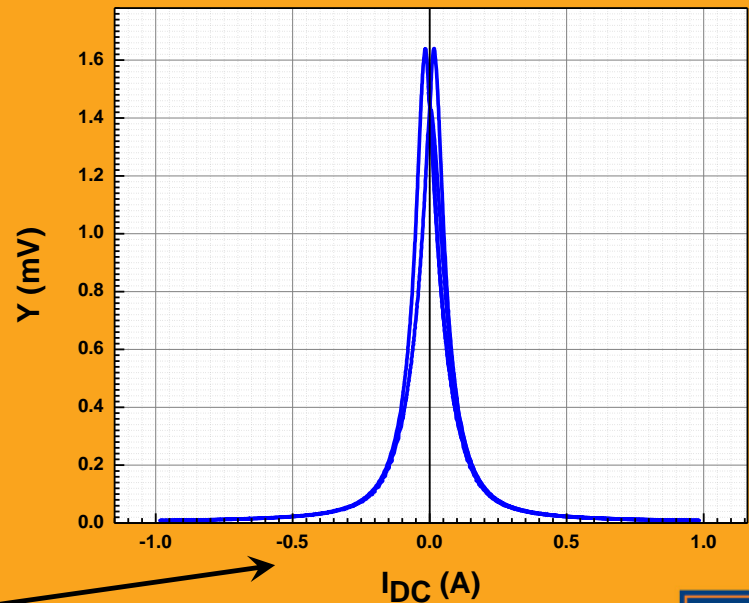

Current in primary coil in A

From permeability to B-H hysteresis loop

Step#3. What we are measuring?
Calibration.

Lock-in measures emf on the pickup coil

$$V_{lock-in} = -\frac{d\Phi}{dt} = -L \frac{dI_p}{dt} = \mu_r L_0 \frac{dI_p}{dt}$$

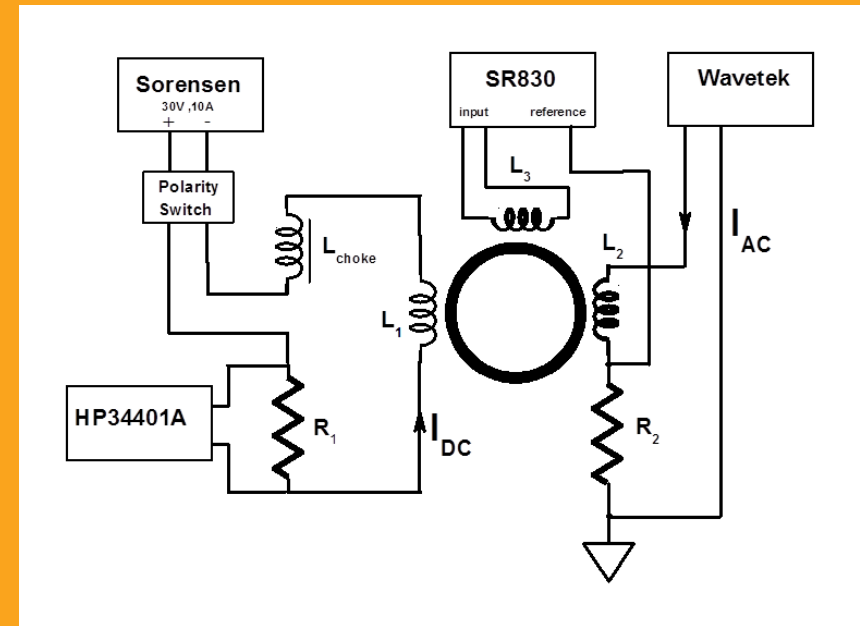

Here I_p is ac current in primary coil L3; $I_p = \frac{V_0 \sin(\omega t)}{R_2}$

From permeability to B-H hysteresis loop

Step#3. What we are measuring?
Calibration.

Primary coil of N_p turns supplied by current I_p creates magnetic field H and flux $d\Phi$

$$\text{For toroid: } H = \frac{N_p I_p}{2\pi r}$$

$$d\Phi = \mu \int \vec{H} \cdot d\vec{a} = \frac{\mu I N t}{2\pi} \int_{R_1}^{R_2} \frac{dr}{r} = \frac{\mu I N t}{2\pi} \ln \frac{R_2}{R_1}$$

$$da = dr * t$$

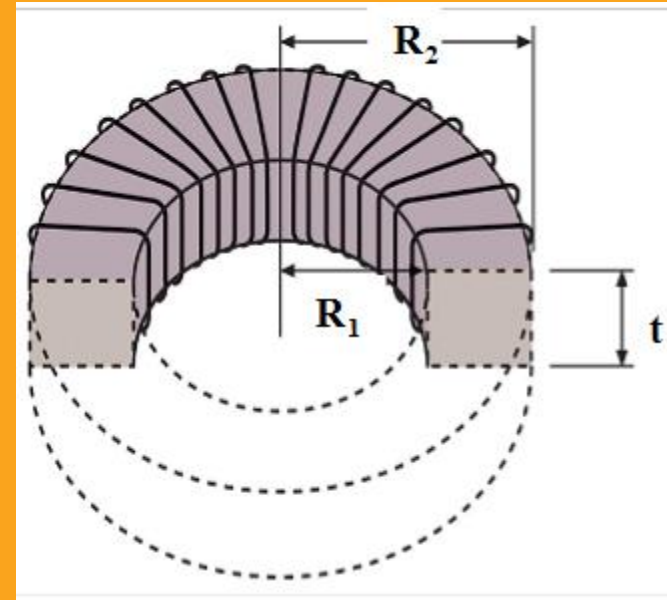

$$R_2 < r < R_1$$

From permeability to B-H hysteresis loop

Step#3. What we are measuring?
Calibration.

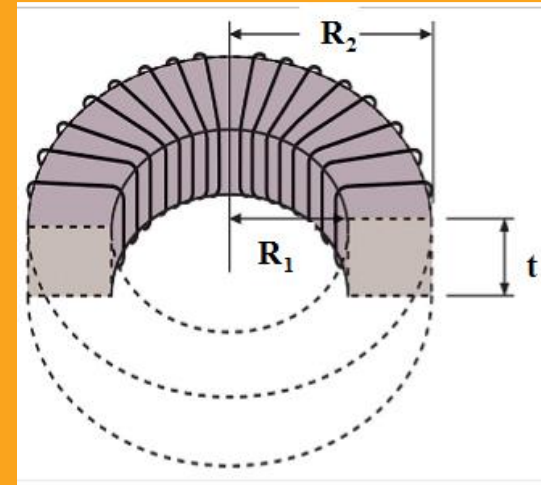

Total flux detected by pickup coil:

$$\Phi = N_{pickup} d\Phi = \frac{\mu N_{pickup} N_p I_p t}{2\pi} \ln \frac{R_2}{R_1}$$

N_p and I_p number of turns of AC primary coil and AC rms current

Inductance of the toroid:

$$L = \frac{\Phi}{I}; \quad L = \mu_r L_0 = (\mu' - i\mu'') L_0$$

$$L_0 = \frac{\mu_0 N_{pickup} N_p t}{2\pi} \ln \frac{R_2}{R_1}$$

From permeability to B-H hysteresis loop

$$V_{lock-in} = \mu_r L_0 \frac{dI_p}{dt}$$

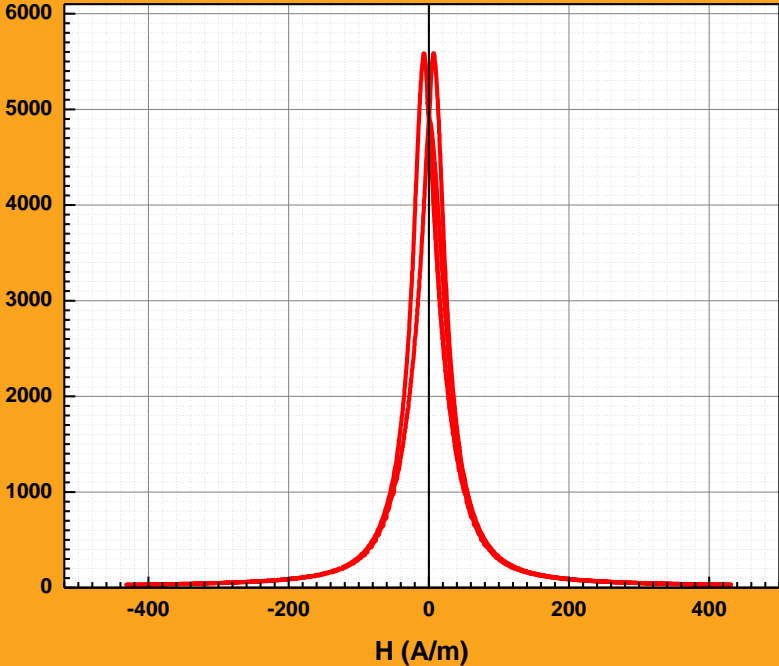
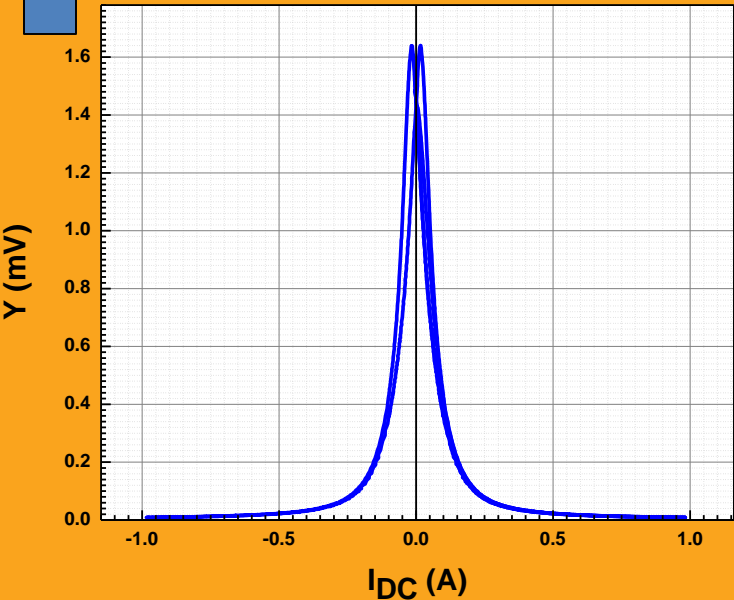

$$H_0 = \frac{N_p I_{DC}}{2\pi r}$$



From permeability to B-H hysteresis loop

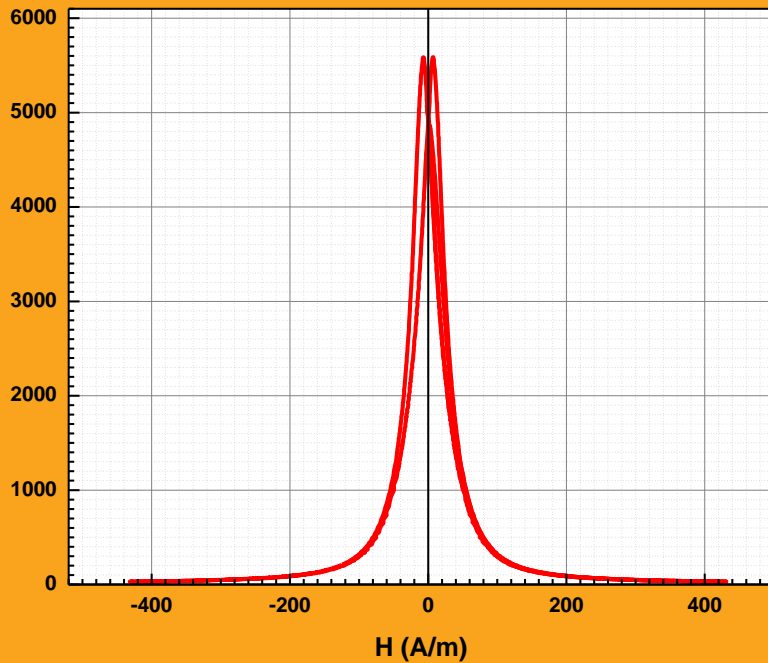

After integrating →

$$B(H) = \mu_0 \int \mu_r(H) dH$$

Step#4. From $\mu_r(H)$ to B-H

$$\mu(H_0) = \mu_0 \mu_r(H_0) = \left. \frac{dB}{dH} \right|_{H_0}$$

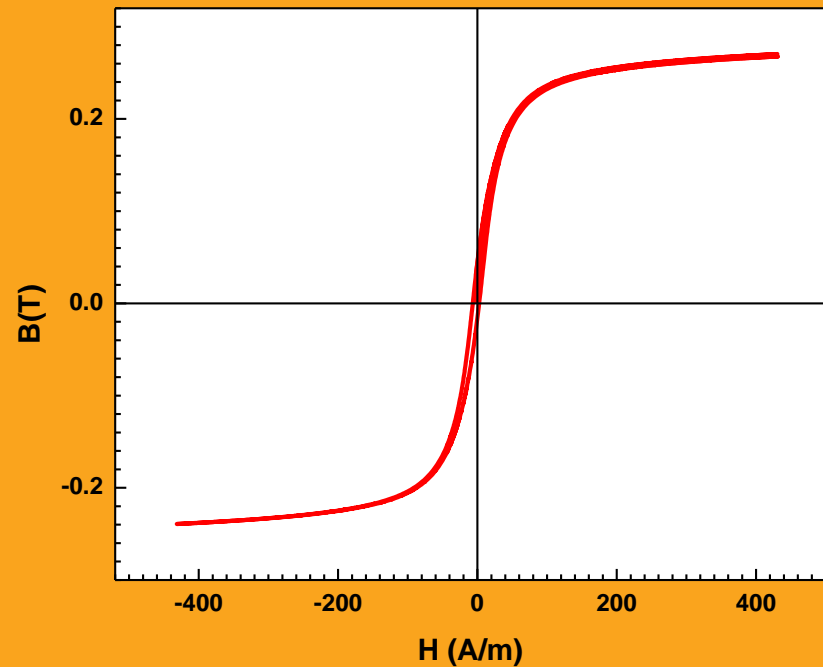

Software issue



Magnetic Lab v9.2

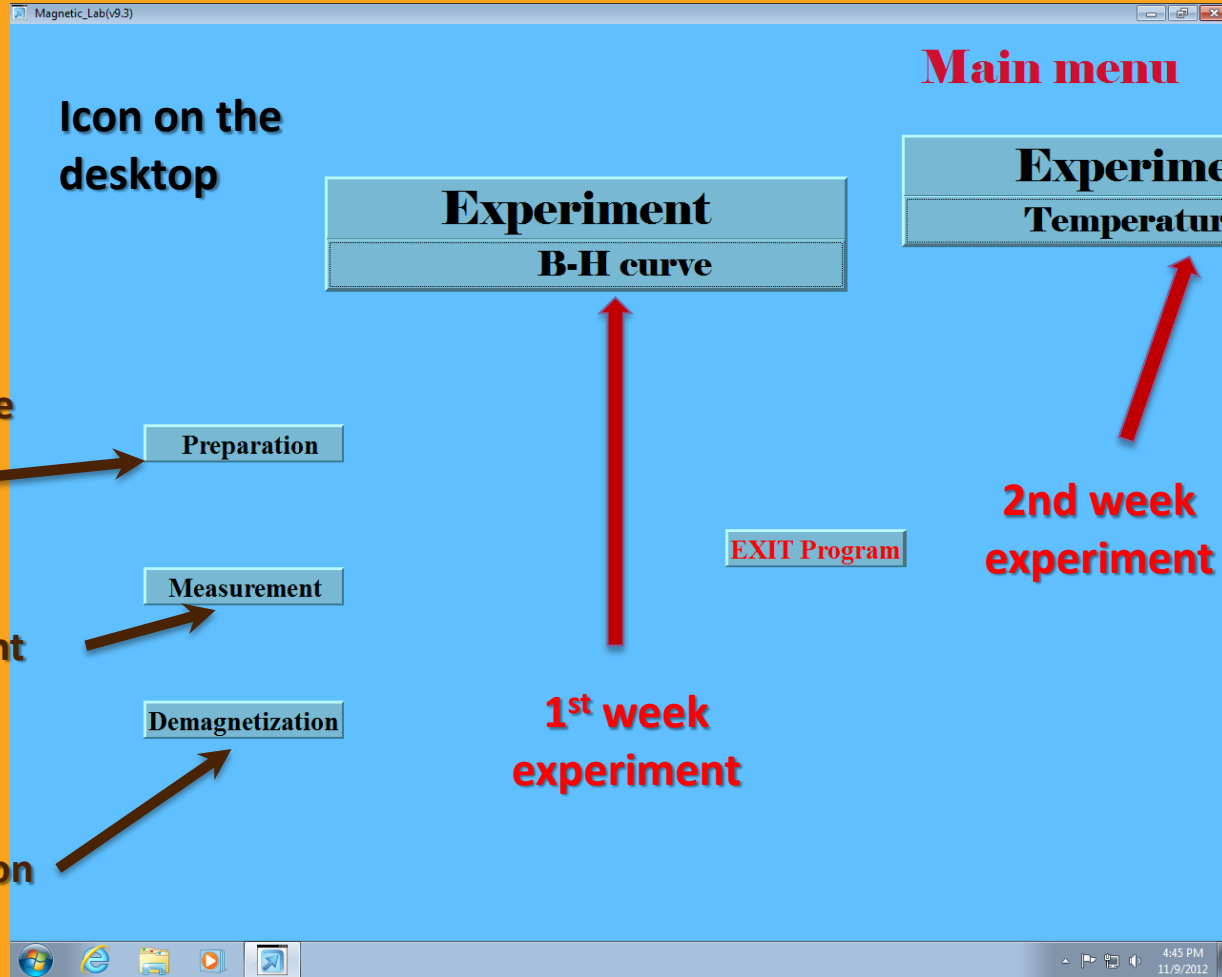

Icon on the desktop

Main menu

Experiment
Temperature scan

Experiment
B-H curve

Preparation of the profile of the experiment

Preparation

B-H measurement

Measurement

Demagnetization

Demagnetization

EXIT Program

2nd week experiment

1st week experiment

Software issue

Measuring profile preparation

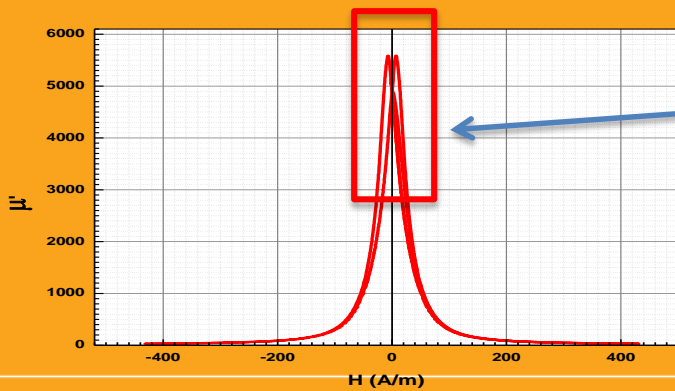
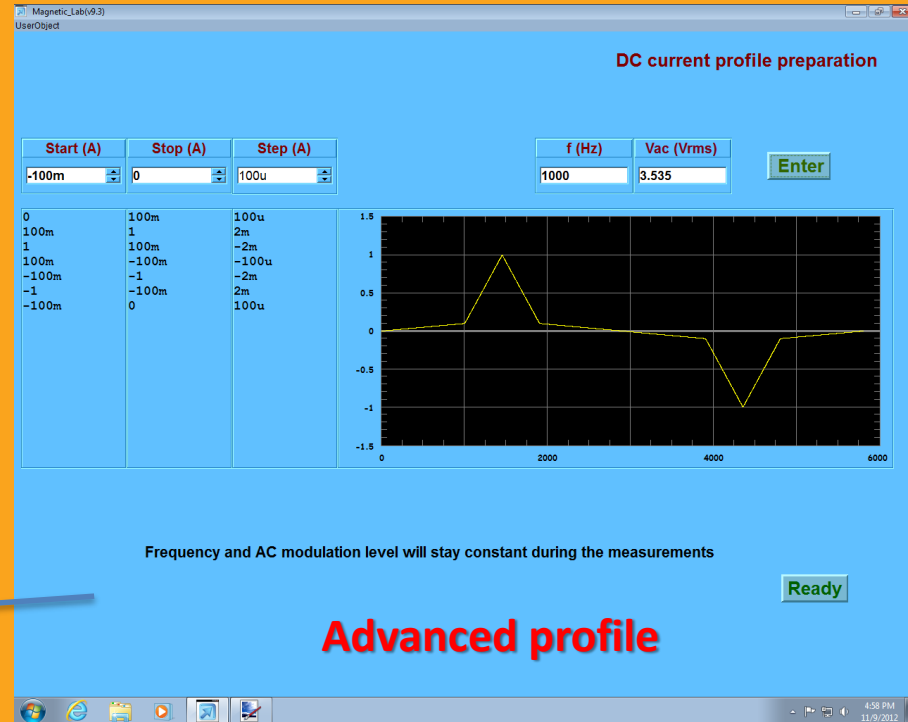
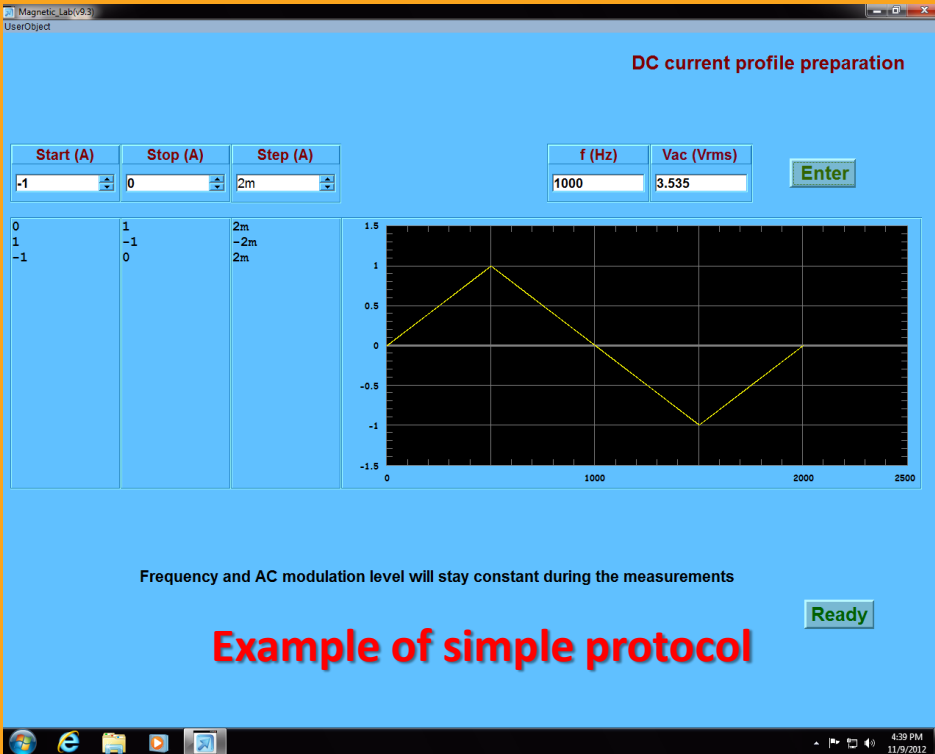

Software issue

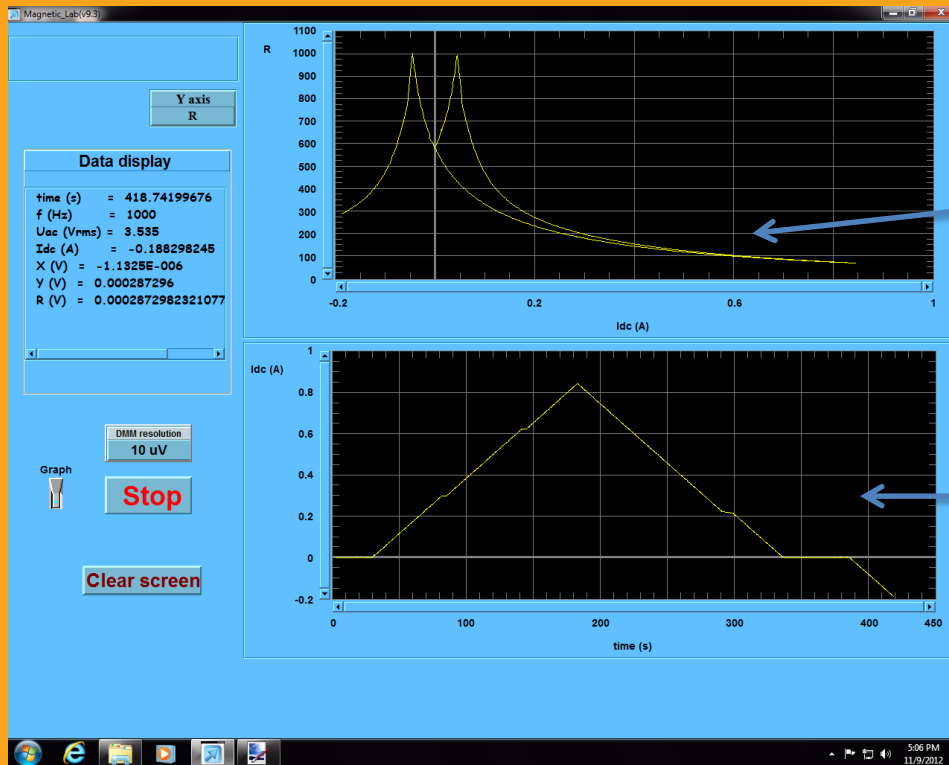

Measurement Window

Lock-in amplifier response

The profile of the applied DC current

Structure of the data file (B-H experiment)

	times(X)	fHz(Y)	UacVrms(Y)	IdcA(Y)	XV(Y)	YV(Y)	RV(Y)
Long	time (s) =	f (Hz) =	Uac (Vrms)	Idc (A) =	X (V) =	Y (V) =	R (V) =
1	2.125	1000	3.535	0.00444	-1.31876E-	7.73077E-	7.73189E-
2	12.828	1000	3.535	0.00416	-1.16975E-	7.72332E-	7.72421E-
3	13.203	1000	3.535	0.00751	-1.1325E-6	7.67563E-	7.67647E-
4	13.578	1000	3.535	0.00988	-1.03564E-	7.65999E-	7.66069E-
5	13.938	1000	3.535	0.01205	-1.15485E-	7.62646E-	7.62733E-
6	14.313	1000	3.535	0.01395	-9.16425E-	7.59815E-	7.5987E-5
7	14.766	1000	3.535	0.01624	-1.22025E-	7.56765E-	7.56865E-



Data analysis using Origin

To calculate the permeability better to use the template :

\\Phyaplportal\PHYCS401\Common\Origin templates\AC magnetic Lab\MU_CALCULATION.otw

It does not contain the equations – you have to write them

	times(X)	f(Hz(Y))	UacVrms(Y)	IdcA(Y)	XV(Y)	YV(Y)	RV(Y)	A(L)	B(Y)	Lo(Y)	mu1(Y)	mu2(Y)	H(Y)
ng N	time (s)	f (Hz)	Uac (Vrms)	Idc (A)	X (V)	Y (V)	R (V)						a/m
Units								Parameters					
1	2.125	1000	3.535	0.00444	-1.31876E-6	7.73077E-5	7.73189E-5	Npickup	20	3.35179E-7	51.92141	0.88571	0.00789
2	12.828	1000	3.535	0.00416	-1.16975E-6	7.72332E-5	7.72421E-5	Nac primary	20	3.35179E-7	51.87137	0.78563	0.00739
3	13.203	1000	3.535	0.00751	-1.1325E-6	7.67563E-5	7.67647E-5	h(m)	0.00825	3.35179E-7	51.55108	0.76061	0.01335
4	13.578	1000	3.535	0.00988	-1.03564E-6	7.65999E-5	7.66069E-5	r2	22.35	3.35179E-7	51.44604	0.69556	0.01756
5	13.938	1000	3.535	0.01205	-1.15485E-6	7.62646E-5	7.62733E-5	r1	13.45	3.35179E-7	51.22084	0.77562	0.02143
6	14.313	1000	3.535	0.01395	-9.16425E-7	7.59815E-5	7.5987E-5	Ndc primary	100	3.35179E-7	51.03071	0.61549	0.0248
7	14.766	1000	3.535	0.01621	-1.22935E-6	7.5676E-5	7.5686E-5				50.82553	0.82566	0.02883
8	15.141	1000	3.535	0.01739	-1.26661E-6	7.51545E-5	7.51652E-5				50.47528	0.85068	0.03092
9	15.484	1000	3.535	0.01974	-8.12117E-6	7.50502E-5	7.50546E-5				50.40523	0.54543	0.0351
10	15.875	1000	3.535	0.02174	-1.1772E-6	7.47894E-5	7.47987E-5				50.23007	0.79063	0.03865
11	16.328	1000	3.535	0.02263	-1.09524E-6	7.46031E-5	7.46111E-5				50.10494	0.73559	0.04025
12	16.703	1000	3.535	0.02589	-9.76033E-6	7.43424E-5	7.43488E-5				49.92985	0.65552	0.04605
13	17.063	1000	3.535	0.02698	-1.15485E-6	7.37687E-5	7.37777E-5				49.54454	0.77562	0.04798



Raw data

Parameters

Calculated results



Data analysis using Origin. Integrating.

$$B(H) = \mu_0 \int \mu_r(H) dH$$

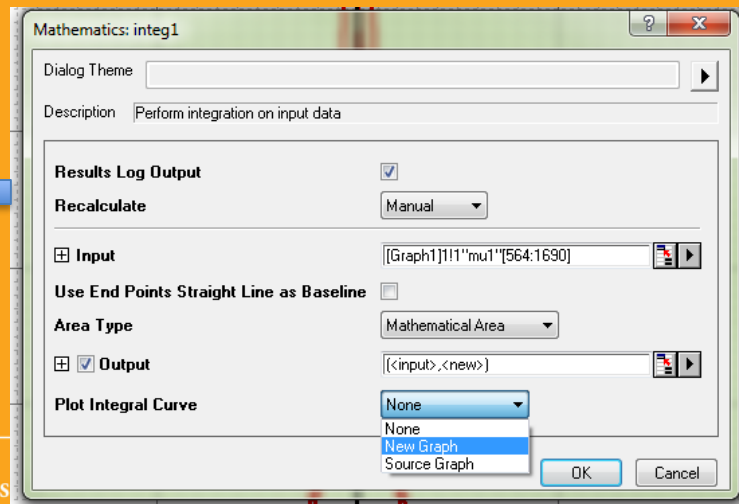
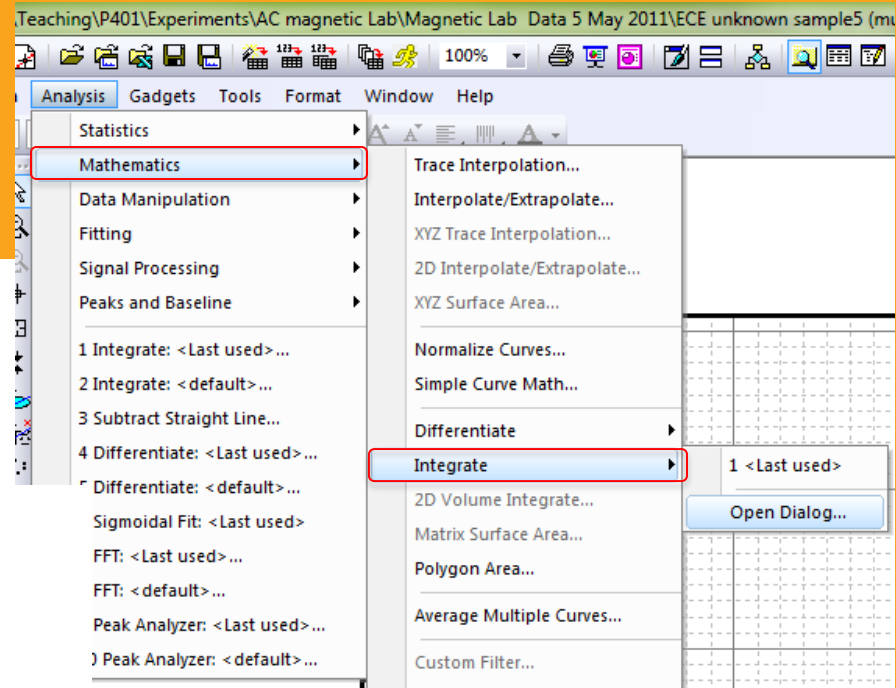
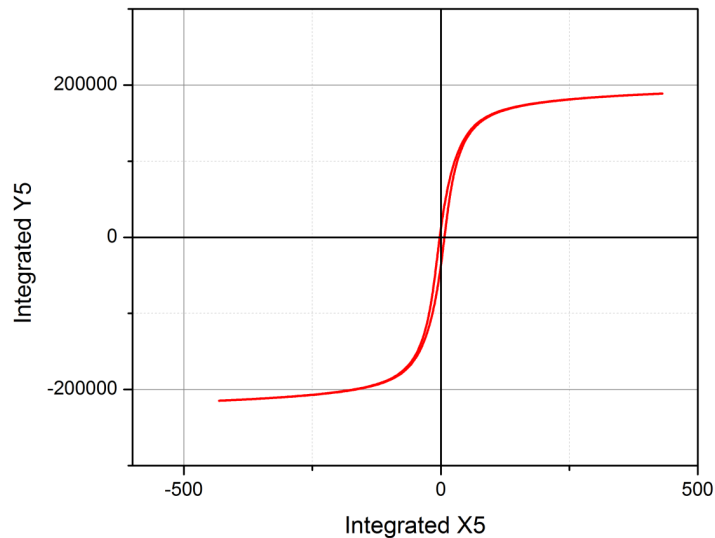

Data analysis using Origin. Integrating.

$$B(H) = \mu_0 \int \mu_r(H) dH + \text{offset}$$

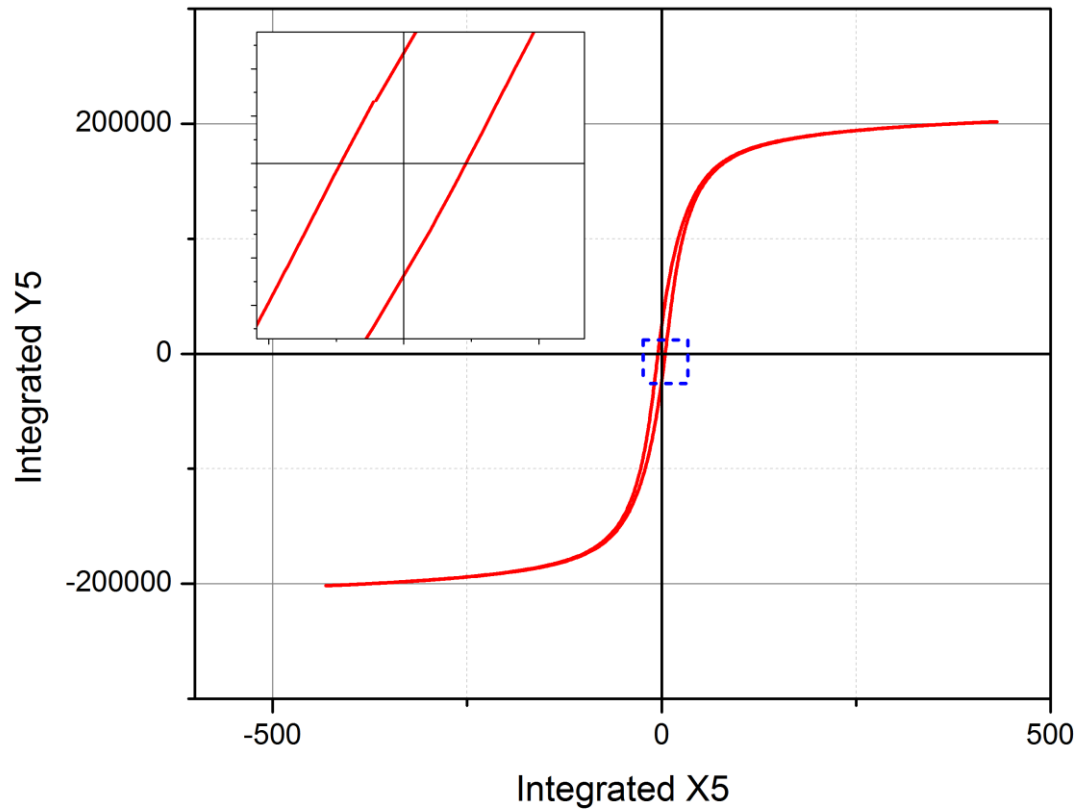

References

- **Information about magnetic materials can be found in :**
\\Phyapportal\PHYCS401\Experiments\AC_Magnetization\Magnetic Materials
- **Chapter from book by D.J. Craik and R.S. Tebble**
“Ferromagnetism and Ferromagnetic domains” link on P401 home page
- **SR830 manual *ibid***

